

FOR PRELIMINARY DESIGN PURPOSES ONLY
DO NOT USE FOR INSTALLATION UNLESS
PART OF CERTIFIED & APPROVED SUBMITTAL

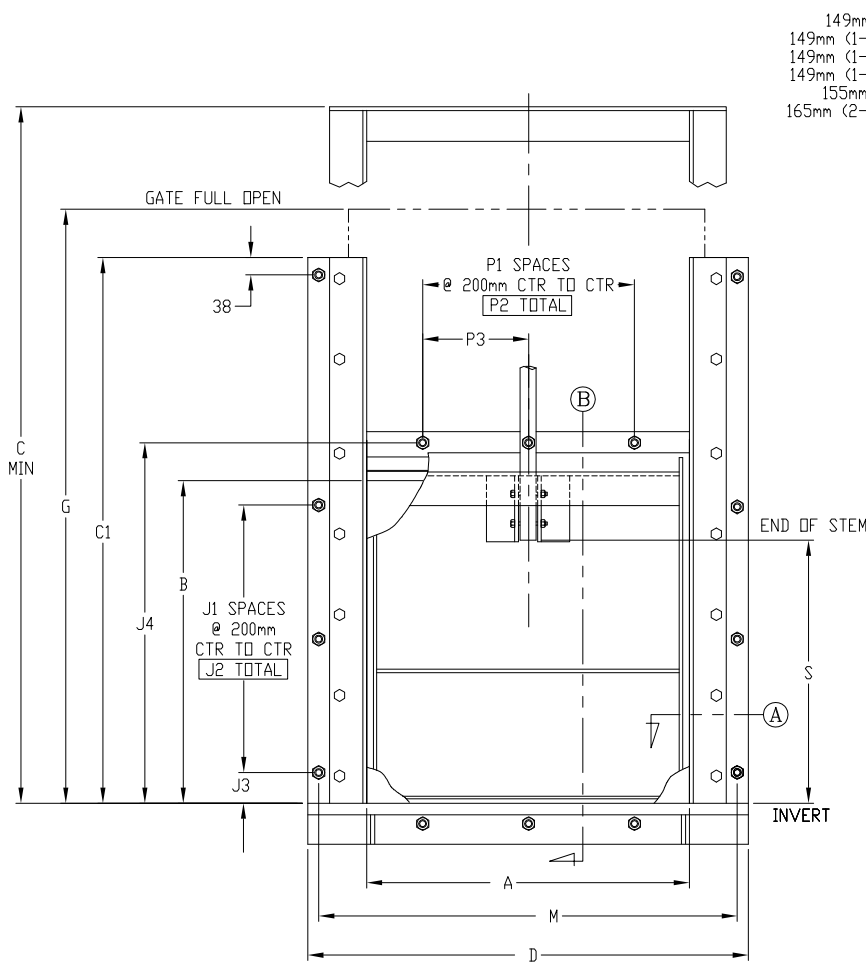

- 149mm (1 DIA STEM)
- 149mm (1-1/8 DIA STEM)
- 149mm (1-1/4 DIA STEM)
- 149mm (1-1/2 DIA STEM)
- 155mm (2 DIA STEM)
- 165mm (2-1/2 DIA STEM)

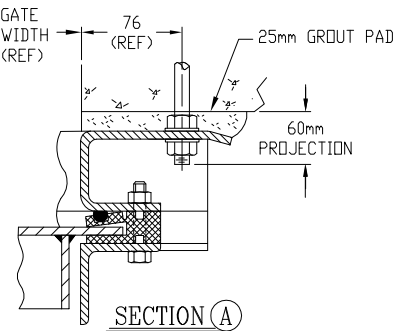
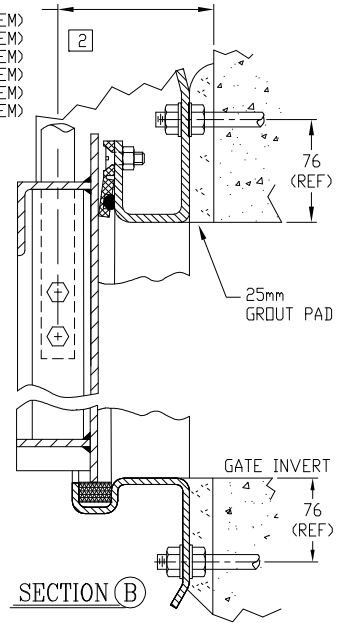

GATE SIZE A x B	C	C1	D	G	J1	J2	J3	J4	M	P1	P2	P3	S	S
													(RS)	(NRS)
200 x 200	668	334	454	464	0	0	100	276	352	0	0	0	52	219
250 x 250	768	417	504	564	1	200	25	326	402	1	200	100	102	269
300 x 300	868	500	554	664	1	200	50	376	452	1	200	100	152	319
300 x 380	1028	634	554	824	1	200	75	456	452	1	200	100	232	399
300 x 450	1168	750	554	964	2	400	25	526	452	1	200	100	302	469
300 x 600	1468	1000	554	1264	2	400	100	676	452	1	200	100	452	619
350 x 350	968	584	604	764	1	200	75	426	502	1	200	100	202	369

[2] ± 4mm ON THE STEM CENTERLINE DIMENSION.

1 ALL DIMENSIONS ARE IN MM

NOTES: UNLESS OTHERWISE SPECIFIED.

REVISION	DATE	APPROVED
DRAWN BY KA	CHECKED BY	
SCALE NONE	DATE 12-01-03	
DRAWING NO. 100506	SHEET 1 OF 7	

SS-271-1

WATERMAN INDUSTRIES OF EGYPT

FOR PRELIMINARY DESIGN PURPOSES ONLY
 DO NOT USE FOR INSTALLATION UNLESS
 PART OF CERTIFIED & APPROVED SUBMITTAL

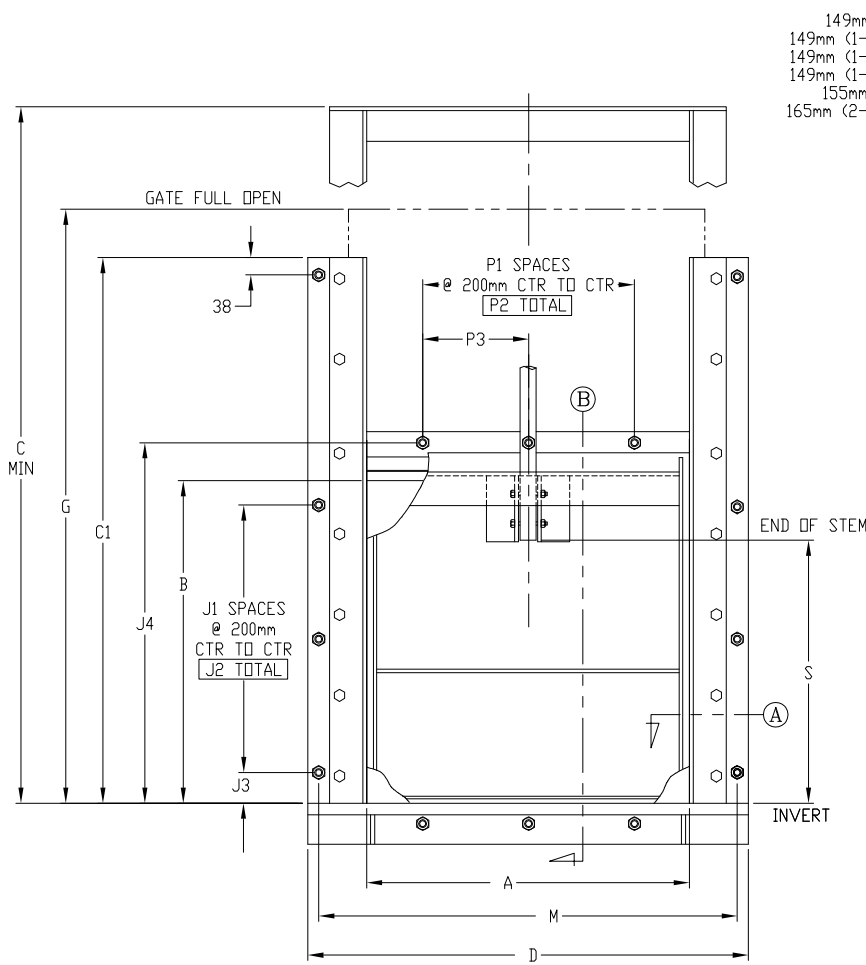

- 149mm (1 DIA STEM)
- 149mm (1-1/8 DIA STEM)
- 149mm (1-1/4 DIA STEM)
- 149mm (1-1/2 DIA STEM)
- 155mm (2 DIA STEM)
- 165mm (2-1/2 DIA STEM)

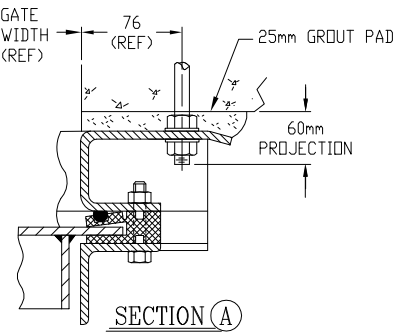
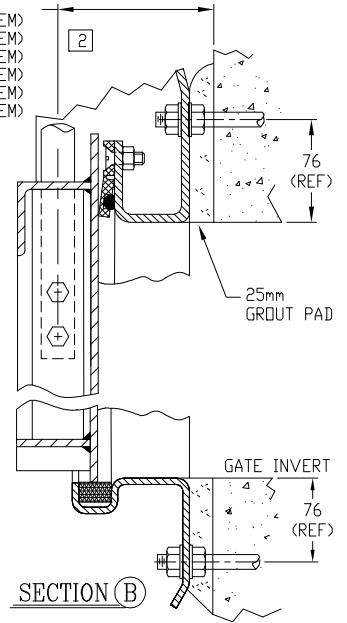

GATE SIZE A x B	C	C1	D	G	J1	J2	J3	J4	M	P1	P2	P3	S	
													(RS)	(NRS)
380 x 300	868	500	634	664	1	200	50	376	532	1	200	100	152	319
380 x 380	1028	634	634	824	1	200	75	456	532	1	200	100	232	399
380 x 450	1168	750	634	964	2	400	25	526	532	1	200	100	302	469
380 x 600	1468	1000	634	1264	2	400	100	676	532	1	200	100	452	619
380 x 750	1768	1250	634	1564	3	600	75	826	532	1	200	100	602	769
400 x 400	1068	667	654	864	1	200	100	476	552	1	200	100	252	419
450 x 300	868	500	704	664	1	200	50	376	602	2	400	200	152	319
450 x 450	1168	750	704	964	2	400	25	526	602	2	400	200	302	469
450 x 600	1468	1000	704	1264	2	400	100	676	602	2	400	200	452	619
450 x 750	1768	1250	704	1564	3	600	75	826	602	2	400	200	602	769
450 x 900	2068	1500	704	1864	4	800	50	976	602	2	400	200	752	919
500 x 500	1268	834	754	1064	2	400	50	576	652	2	400	200	352	519
530 x 530	1328	884	784	1124	2	400	50	606	682	2	400	200	382	549

[2] ± 4mm ON THE STEM CENTERLINE DIMENSION.
 1 ALL DIMENSIONS ARE IN MM
 NOTES: UNLESS OTHERWISE SPECIFIED.

SS-271-1

REVISION	DATE	APPROVED
DRAWN BY KA	CHECKED BY	
SCALE NONE	DATE 12-01-03	
DRAWING NO. 100506	SHEET 2 OF 7	

FOR PRELIMINARY DESIGN PURPOSES ONLY
DO NOT USE FOR INSTALLATION UNLESS
PART OF CERTIFIED & APPROVED SUBMITTAL

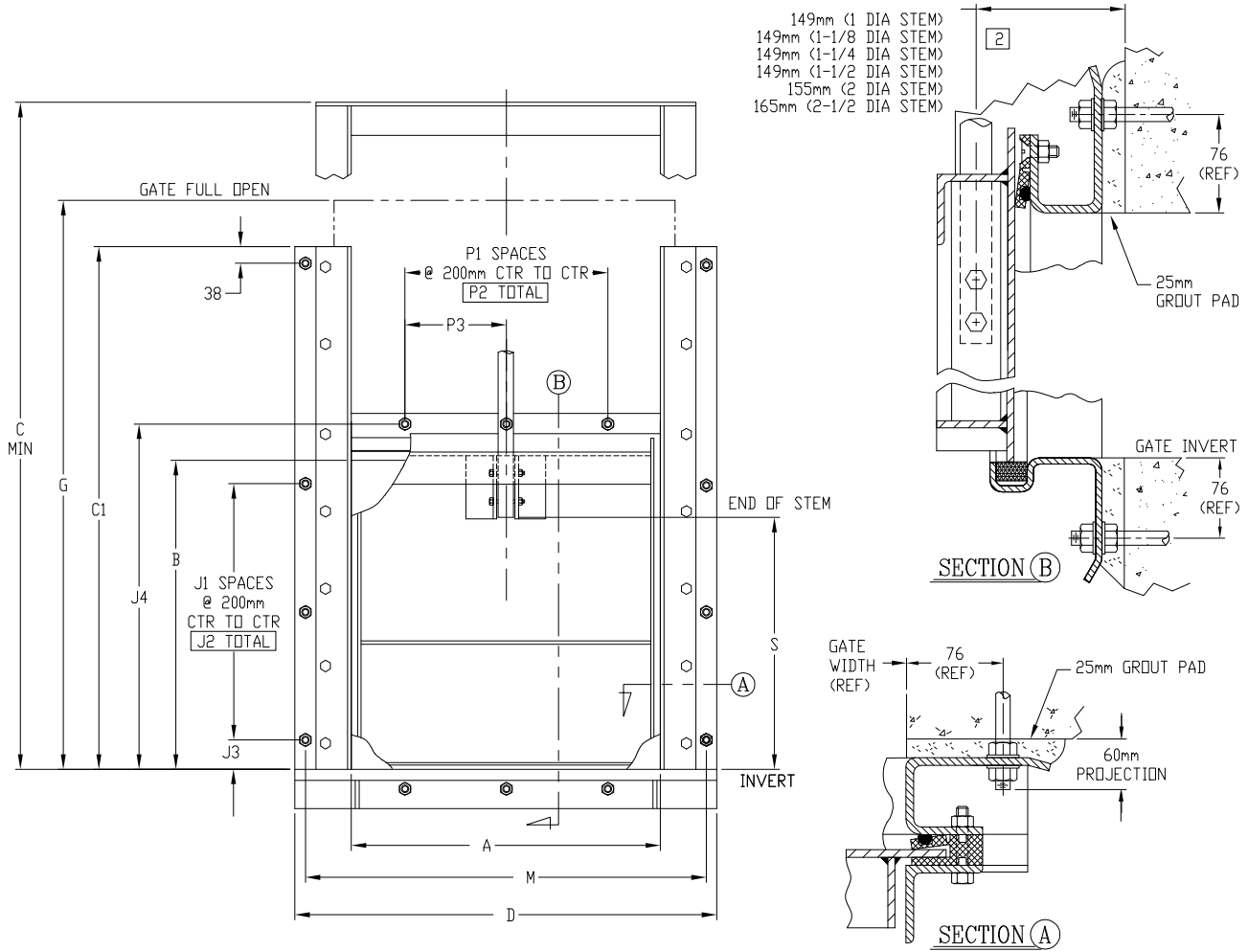

GATE SIZE A x B	C	C1	D	G	J1	J2	J3	J4	M	P1	P2	P3	S	
													(RS)	(NRS)
600 x 300	868	500	854	664	1	200	50	376	752	2	400	200	152	319
600 x 450	1168	750	854	964	2	400	25	526	752	2	400	200	302	469
600 x 600	1468	1000	854	1264	2	400	100	676	752	2	400	200	452	619
600 x 750	1768	1250	854	1564	3	600	75	826	752	2	400	200	602	769
600 x 900	2068	1500	854	1864	4	800	50	976	752	2	400	200	752	919
600 x 1050	2368	1750	854	2164	5	1000	25	1126	752	2	400	200	902	1069
600 x 1200	2668	2000	854	2464	5	1000	100	1276	752	2	400	200	1052	1219
700 x 700	1668	1167	954	1464	3	600	50	776	852	3	600	300	552	719
750 x 450	1168	750	1004	964	2	400	25	526	902	3	600	300	302	469
750 x 600	1468	1000	1004	1264	2	400	100	676	902	3	600	300	452	619
750 x 750	1768	1250	1004	1564	3	600	75	826	902	3	600	300	602	769
750 x 900	2068	1500	1004	1864	4	800	50	976	902	3	600	300	752	919
750 x 1050	2368	1750	1004	2164	5	1000	25	1126	902	3	600	300	902	1069
750 x 1200	2668	2000	1004	2464	5	1000	100	1276	902	3	600	300	1052	1219
750 x 1370	3008	2284	1004	2804	6	1200	75	1446	902	3	600	300	1222	1389
750 x 1500	3268	2500	1004	3064	7	1400	50	1576	902	3	600	300	1352	1519
800 x 800	1868	1334	1054	1664	3	600	100	876	952	3	600	300	652	819

[2] ± 4mm ON THE STEM CENTERLINE DIMENSION.
1 ALL DIMENSIONS ARE IN MM
NOTES: UNLESS OTHERWISE SPECIFIED.

SS-271-1

REVISION	DATE	APPROVED
DRAWN BY KA	CHECKED BY	
SCALE NONE	DATE 12-01-03	
DRAWING NO. 100506	SHEET 3 OF 7	

WATERMAN INDUSTRIES OF EGYPT

FOR PRELIMINARY DESIGN PURPOSES ONLY
DO NOT USE FOR INSTALLATION UNLESS
PART OF CERTIFIED & APPROVED SUBMITTAL

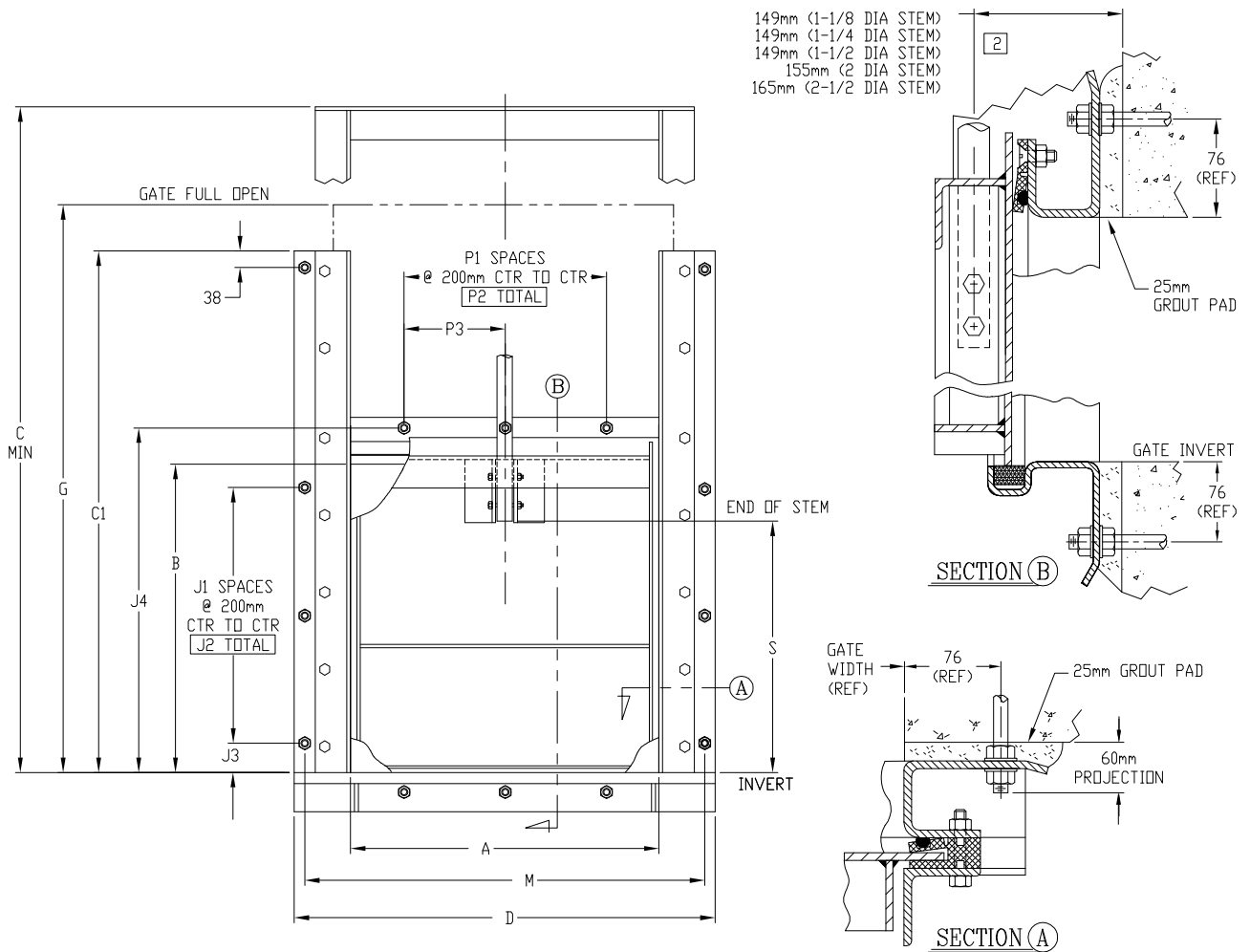

GATE SIZE A x B	C	C1	D	G	J1	J2	J3	J4	M	P1	P2	P3	S	S
													(RS)	(NRS)
900 x 450	1168	750	1154	964	2	400	25	526	1052	4	800	400	302	469
900 x 600	1468	1000	1154	1264	2	400	100	676	1052	4	800	400	452	619
900 x 750	1768	1250	1154	1564	3	600	75	826	1052	4	800	400	602	769
900 x 900	2068	1500	1154	1864	4	800	50	976	1052	4	800	400	752	919
900 x 1050	2368	1750	1154	2164	5	1000	25	1126	1052	4	800	400	902	1069
900 x 1200	2668	2000	1154	2464	5	1000	100	1276	1052	4	800	400	1052	1219
900 x 1370	3008	2284	1154	2804	6	1200	75	1446	1052	4	800	400	1222	1389
900 x 1500	3268	2500	1154	3064	7	1400	50	1576	1052	4	800	400	1352	1519
900 x 1670	3608	2784	1154	3404	8	1600	25	1746	1052	4	800	400	1522	1689
900 x 1800	3868	3000	1154	3664	8	1600	100	1876	1052	4	800	400	1652	1819
1000 x 1000	2268	1667	1254	2064	4	800	100	1076	1152	4	800	400	852	1019
1050 x 600	1468	1000	1304	1264	2	400	100	676	1202	5	1000	500	452	619
1050 x 750	1768	1250	1304	1564	3	600	75	826	1202	5	1000	500	602	769
1050 x 900	2068	1500	1304	1864	4	800	50	976	1202	5	1000	500	752	919
1050 x 1050	2368	1750	1304	2164	5	1000	25	1126	1202	5	1000	500	902	1069
1050 x 1200	2668	2000	1304	2464	5	1000	100	1276	1202	5	1000	500	1052	1219
1050 x 1370	3008	2284	1304	2804	6	1200	75	1446	1202	5	1000	500	1222	1389
1050 x 1500	3268	2500	1304	3064	7	1400	50	1576	1202	5	1000	500	1352	1519
1050 x 1670	3608	2784	1304	3404	8	1600	25	1746	1202	5	1000	500	1522	1689
1050 x 1800	3868	3000	1304	3664	8	1600	100	1876	1202	5	1000	500	1652	1819

[2] ± 4mm ON THE STEM CENTERLINE DIMENSION.

1 ALL DIMENSIONS ARE IN MM

NOTES: UNLESS OTHERWISE SPECIFIED.

SS-271-1

REVISION	DATE	APPROVED
DRAWN BY KA	CHECKED BY	
SCALE NONE	DATE 12-01-03	
DRAWING NO. 100506	SHEET 4 OF 7	

WATERMAN INDUSTRIES OF EGYPT

FOR PRELIMINARY DESIGN PURPOSES ONLY
 DO NOT USE FOR INSTALLATION UNLESS
 PART OF CERTIFIED & APPROVED SUBMITTAL

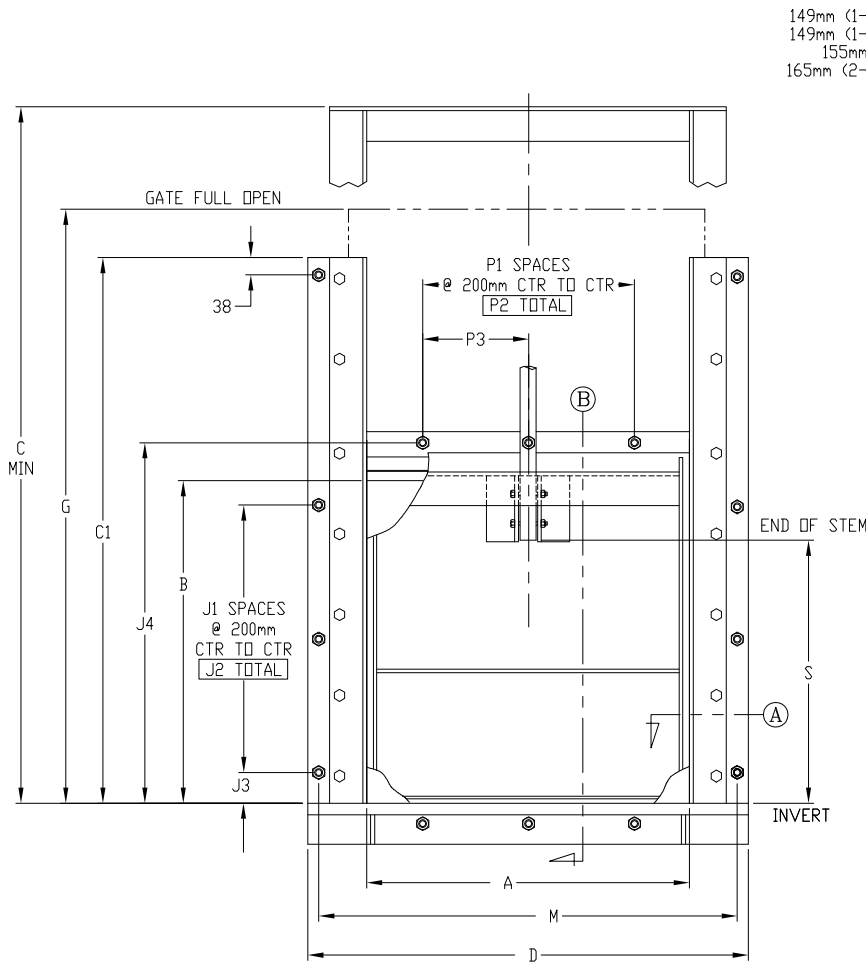

149mm (1-1/4 DIA STEM)
 149mm (1-1/2 DIA STEM)
 155mm (2 DIA STEM)
 165mm (2-1/2 DIA STEM)

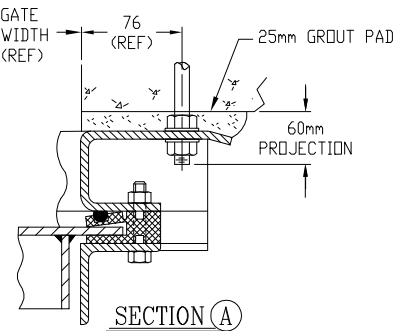
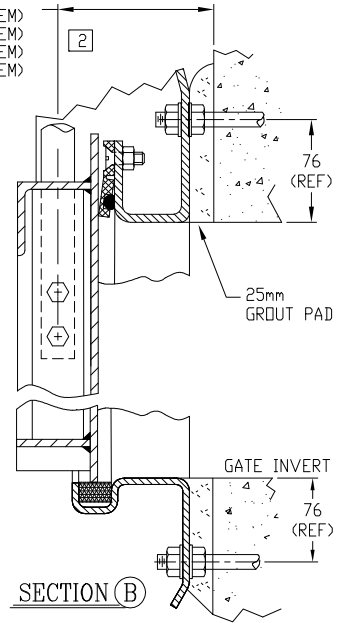

GATE SIZE A x B	C	C1	D	G	J1	J2	J3	J4	M	P1	P2	P3	S	S
													(RS)	(NRS)
1100 x 1100	2468	1834	1354	2264	5	1000	50	1176	1252	5	1000	500	952	1119
1200 x 600	1468	1000	1454	1264	2	400	100	676	1352	5	1000	500	452	619
1200 x 750	1768	1250	1454	1564	3	600	75	826	1352	5	1000	500	602	769
1200 x 900	2068	1500	1454	1864	4	800	50	976	1352	5	1000	500	752	919
1200 x 1050	2368	1750	1454	2164	5	1000	25	1126	1352	5	1000	500	902	1069
1200 x 1200	2668	2000	1454	2464	5	1000	100	1276	1352	5	1000	500	1052	1219
1200 x 1370	3008	2284	1454	2804	6	1200	75	1446	1352	5	1000	500	1222	1389
1200 x 1500	3268	2500	1454	3064	7	1400	50	1576	1352	5	1000	500	1352	1519
1200 x 1670	3608	2784	1454	3404	8	1600	25	1746	1352	5	1000	500	1522	1689
1200 x 1800	3868	3000	1454	3664	8	1600	100	1876	1352	5	1000	500	1652	1819
1300 x 1300	2868	2167	1554	2664	6	1200	50	1376	1452	6	1200	600	1152	1319
1370 x 750	1768	1250	1624	1564	3	600	75	826	1522	6	1200	600	602	769
1370 x 900	2068	1500	1624	1864	4	800	50	976	1522	6	1200	600	752	919
1370 x 1050	2368	1750	1624	2164	5	1000	25	1126	1522	6	1200	600	902	1069
1370 x 1200	2668	2000	1624	2464	5	1000	100	1276	1522	6	1200	600	1052	1219
1370 x 1370	3008	2284	1624	2804	6	1200	75	1446	1522	6	1200	600	1222	1389
1370 x 1500	3268	2500	1624	3064	7	1400	50	1576	1522	6	1200	600	1352	1519
1370 x 1670	3608	2784	1624	3404	8	1600	25	1746	1522	6	1200	600	1522	1689
1370 x 1800	3868	3000	1624	3664	8	1600	100	1876	1522	6	1200	600	1652	1819

[2] ± 4mm ON THE STEM CENTERLINE DIMENSION.
 1 ALL DIMENSIONS ARE IN MM
 NOTES: UNLESS OTHERWISE SPECIFIED.

SS-271-1

REVISION	DATE	APPROVED
DRAWN BY KA	CHECKED BY	
SCALE NONE	DATE 12-01-03	
DRAWING NO. 100506	SHEET 5 OF 7	

WATERMAN INDUSTRIES OF EGYPT

FOR PRELIMINARY DESIGN PURPOSES ONLY
 DO NOT USE FOR INSTALLATION UNLESS
 PART OF CERTIFIED & APPROVED SUBMITTAL

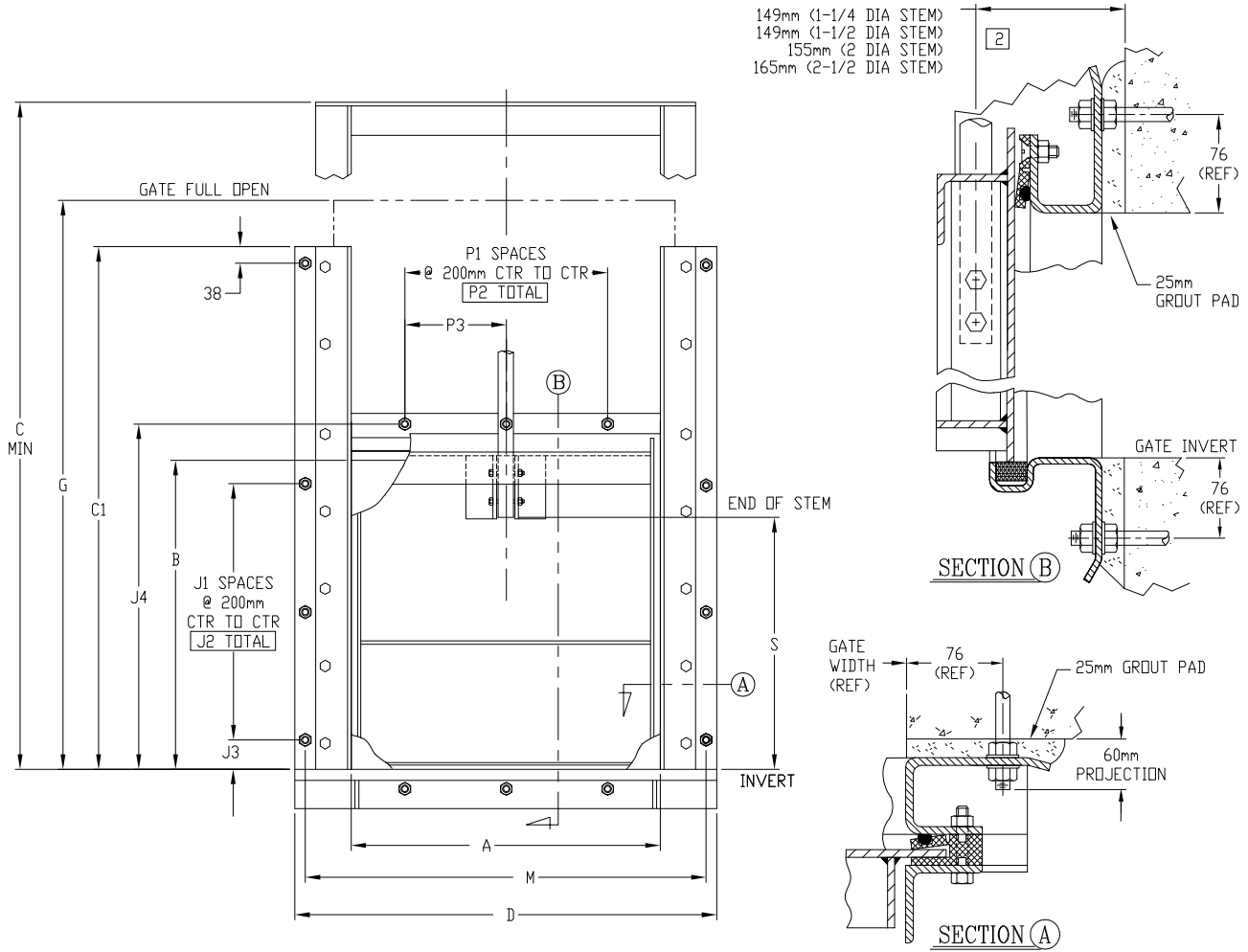

GATE SIZE A x B	C	C1	D	G	J1	J2	J3	J4	M	P1	P2	P3	S	
													(RS)	(NRS)
1400 x 1400	3068	2334	1654	2864	6	1200	100	1476	1552	6	1200	600	1252	1419
1500 x 750	1768	1250	1754	1564	3	600	75	826	1652	7	1400	700	602	769
1500 x 900	2068	1500	1754	1864	4	800	50	976	1652	7	1400	700	752	919
1500 x 1050	2368	1750	1754	2164	5	1000	25	1126	1652	7	1400	700	902	1069
1500 x 1200	2668	2000	1754	2464	5	1000	100	1276	1652	7	1400	700	1052	1219
1500 x 1370	3008	2284	1754	2804	6	1200	75	1446	1652	7	1400	700	1222	1389
1500 x 1500	3268	2500	1754	3064	7	1400	50	1576	1652	7	1400	700	1352	1519
1500 x 1670	3608	2784	1754	3404	8	1600	25	1746	1652	7	1400	700	1522	1689
1500 x 1800	3868	3000	1754	3664	8	1600	100	1876	1652	7	1400	700	1652	1819

[2] ± 4mm ON THE STEM CENTERLINE DIMENSION.
 1 ALL DIMENSIONS ARE IN MM
 NOTES: UNLESS OTHERWISE SPECIFIED.

REVISION	DATE	APPROVED
DRAWN BY KA	CHECKED BY	
SCALE NONE	DATE 12-01-03	
DRAWING NO. 100506	SHEET 6 OF 7	

SS-271-1

FOR PRELIMINARY DESIGN PURPOSES ONLY
DO NOT USE FOR INSTALLATION UNLESS
PART OF CERTIFIED & APPROVED SUBMITTAL

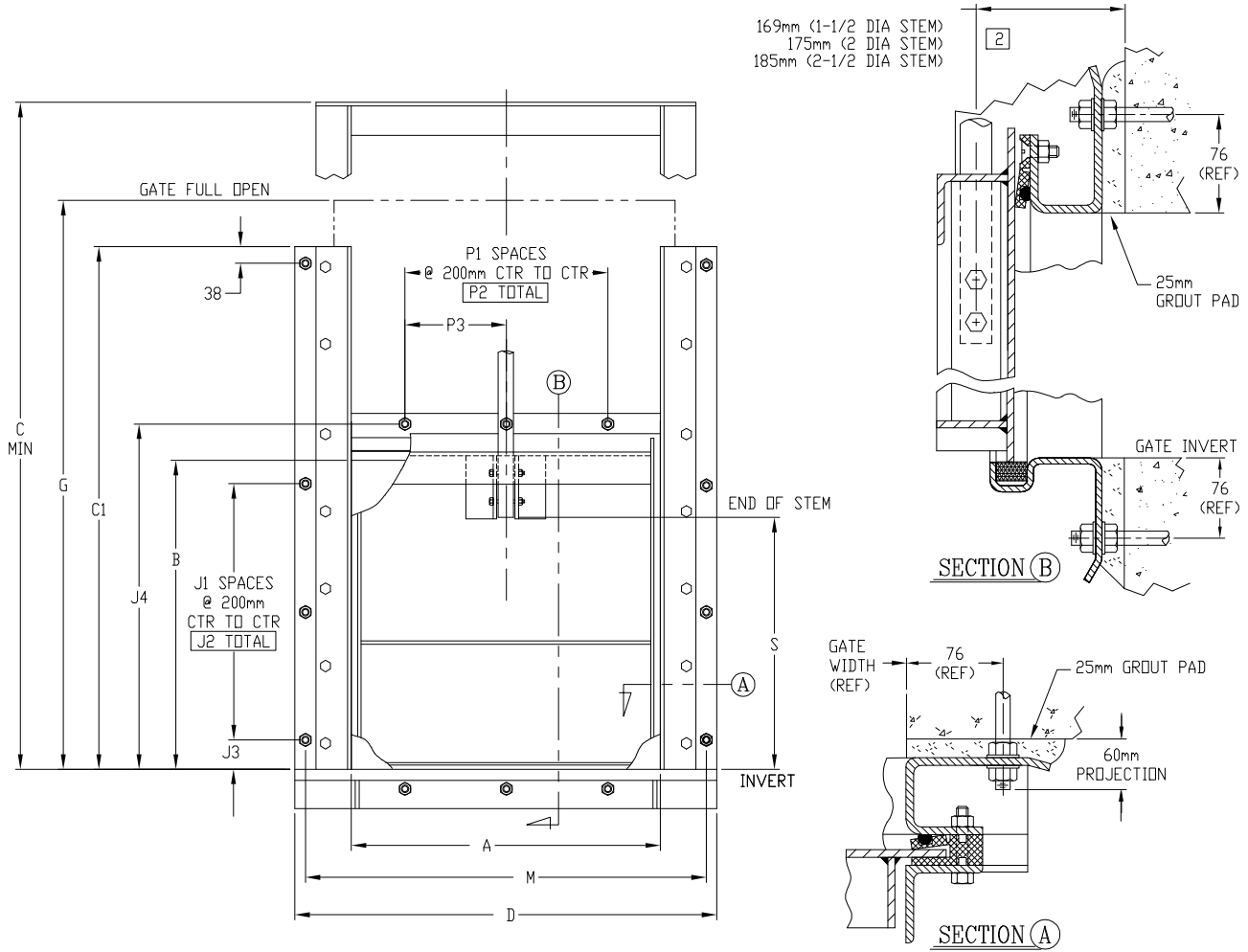

GATE SIZE A x B	C	C1	D	G	J1	J2	J3	J4	M	P1	P2	P3	S	
													(RS)	(NRS)
1600 x 1600	3474	2667	1892	3270	7	1400	100	1676	1752	7	1400	700	1452	1619
1670 x 900	2074	1500	1962	1870	4	800	50	976	1822	8	1600	800	752	919
1670 x 1050	2374	1750	1962	2170	5	1000	25	1126	1822	8	1600	800	902	1069
1670 x 1200	2674	2000	1962	2470	5	1000	100	1276	1822	8	1600	800	1052	1219
1670 x 1370	3014	2284	1962	2810	6	1200	75	1446	1822	8	1600	800	1222	1389
1670 x 1500	3274	2500	1962	3070	7	1400	50	1576	1822	8	1600	800	1352	1519
1670 x 1670	3614	2784	1962	3410	8	1600	25	1746	1822	8	1600	800	1522	1689
1670 x 1800	3874	3000	1962	3670	8	1600	100	1876	1822	8	1600	800	1652	1819
1700 x 1700	3674	2834	1992	3470	8	1600	50	1776	1852	8	1600	800	1552	1719
1800 x 900	2074	1500	2092	1870	4	800	50	976	1952	8	1600	800	752	919
1800 x 1050	2374	1750	2092	2170	5	1000	25	1126	1952	8	1600	800	902	1069
1800 x 1200	2674	2000	2092	2470	5	1000	100	1276	1952	8	1600	800	1052	1219
1800 x 1370	3014	2284	2092	2810	6	1200	75	1446	1952	8	1600	800	1222	1389
1800 x 1500	3274	2500	2092	3070	7	1400	50	1576	1952	8	1600	800	1352	1519
1800 x 1670	3614	2784	2092	3410	8	1600	25	1746	1952	8	1600	800	1522	1689
1800 x 1800	3874	3000	2092	3670	8	1600	100	1876	1952	8	1600	800	1652	1819

* STANDARD SIZES UPTO 1800mm x 1800mm ARE SHOWN. CONTACT THE FACTORY FOR OTHER SIZES.

[2] ± 4mm ON THE STEM CENTERLINE DIMENSION.

1 ALL DIMENSIONS ARE IN MM

NOTES: UNLESS OTHERWISE SPECIFIED.

SS-271-1

REVISION	DATE	APPROVED
DRAWN BY KA	CHECKED BY	
SCALE NONE	DATE 12-01-03	
DRAWING NO. 100506	SHEET 7 OF 7	

WATERMAN INDUSTRIES OF EGYPT