

FOR PRELIMINARY DESIGN PURPOSES ONLY
DO NOT USE FOR INSTALLATION UNLESS
PART OF CERTIFIED & APPROVED SUBMITTAL

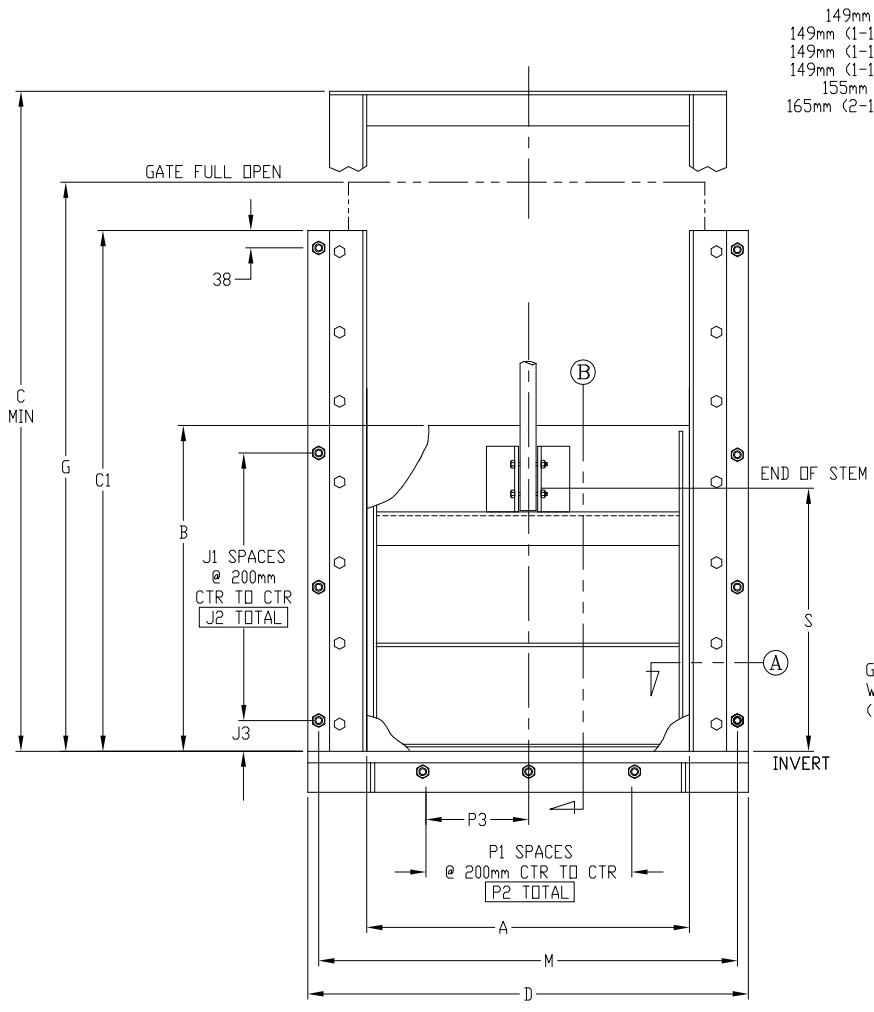

- 149mm (1 DIA STEM)
- 149mm (1-1/8 DIA STEM)
- 149mm (1-1/4 DIA STEM)
- 149mm (1-1/2 DIA STEM)
- 155mm (2 DIA STEM)
- 165mm (2-1/2 DIA STEM)

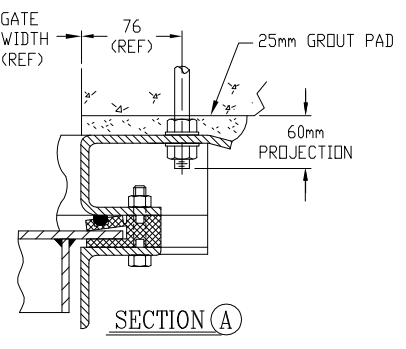
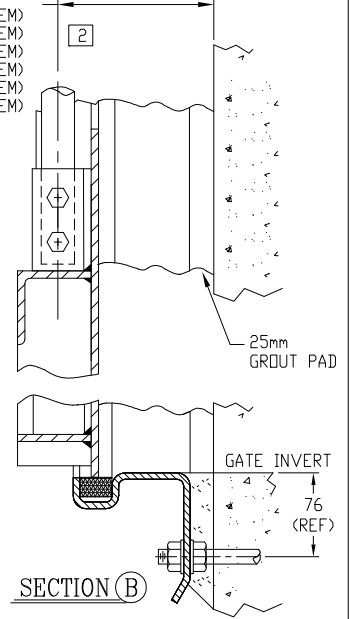

GATE SIZE A x B	C	C1	D	G	J1	J2	J3	M	P1	P2	P3	S
												(RS)
200 x 200	604	334	454	400	0	0	100	352	0	0	0	54
250 x 250	704	417	504	500	1	200	25	402	1	200	100	102
300 x 300	804	500	554	600	1	200	50	452	1	200	100	152
300 x 380	964	634	554	760	1	200	75	452	1	200	100	232
300 x 450	1104	750	554	900	2	400	25	452	1	200	100	302
300 x 600	1404	1000	554	1200	2	400	100	452	1	200	100	452
350 x 350	904	584	604	700	1	200	75	502	1	200	100	202

[2] ± 4mm ON THE STEM CENTERLINE DIMENSION.
1 ALL DIMENSIONS ARE IN MM
NOTES: UNLESS OTHERWISE SPECIFIED.

REVISION	DATE	APPROVED
DRAWN BY KA	CHECKED BY	
SCALE NONE	DATE 27-08-06	
DRAWING NO. 100509	SHEET 1 OF 7	

SS-253-1

FOR PRELIMINARY DESIGN PURPOSES ONLY
DO NOT USE FOR INSTALLATION UNLESS
PART OF CERTIFIED & APPROVED SUBMITTAL

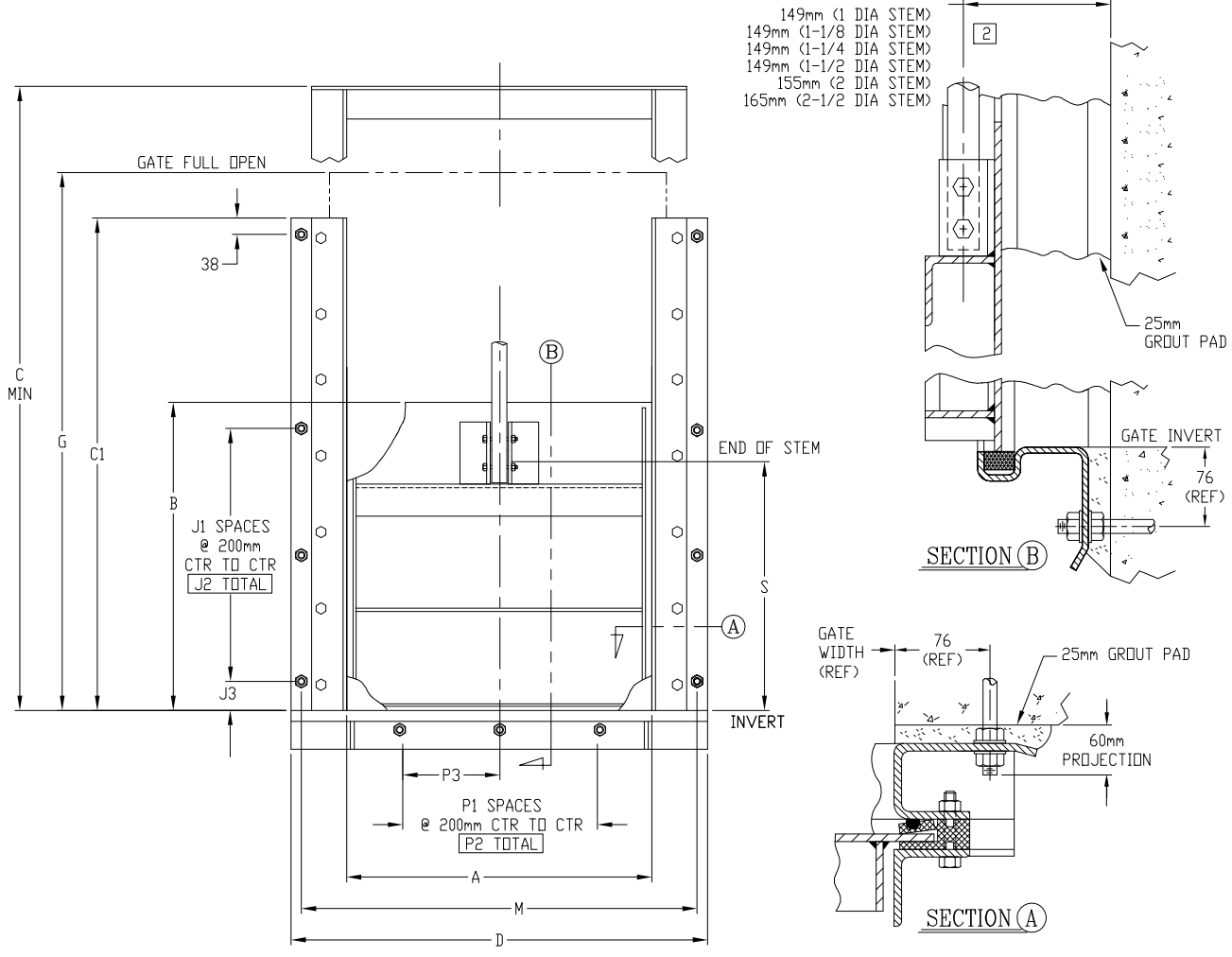

GATE SIZE A x B	C	C1	D	G	J1	J2	J3	M	P1	P2	P3	S (RS)
380 x 300	804	500	634	600	1	200	50	532	1	200	100	152
380 x 380	964	634	634	760	1	200	75	532	1	200	100	232
380 x 450	1104	750	634	900	2	400	25	532	1	200	100	302
380 x 600	1404	1000	634	1200	2	400	100	532	1	200	100	452
380 x 750	1704	1250	634	1500	3	600	75	532	1	200	100	602
400 x 400	1004	667	654	800	1	200	100	552	1	200	100	252
450 x 300	804	500	704	600	1	200	50	602	2	400	200	152
450 x 450	1104	750	704	900	2	400	25	602	2	400	200	302
450 x 600	1404	1000	704	1200	2	400	100	602	2	400	200	452
450 x 750	1704	1250	704	1500	3	600	75	602	2	400	200	602
450 x 900	2004	1500	704	1800	4	800	50	602	2	400	200	752
500 x 500	1204	834	754	1000	2	400	50	652	2	400	200	352
530 x 530	1264	884	784	1060	2	400	50	682	2	400	200	382
600 x 300	804	500	854	600	1	200	50	752	2	400	200	152

[2] ± 4mm ON THE STEM CENTERLINE DIMENSION.
1 ALL DIMENSIONS ARE IN MM
NOTES: UNLESS OTHERWISE SPECIFIED.

SS-253-1

REVISION	DATE	APPROVED
DRAWN BY KA	CHECKED BY	
SCALE NONE	DATE 27-08-06	
DRAWING NO. 100509	SHEET 2 OF 7	

FOR PRELIMINARY DESIGN PURPOSES ONLY
DO NOT USE FOR INSTALLATION UNLESS
PART OF CERTIFIED & APPROVED SUBMITTAL

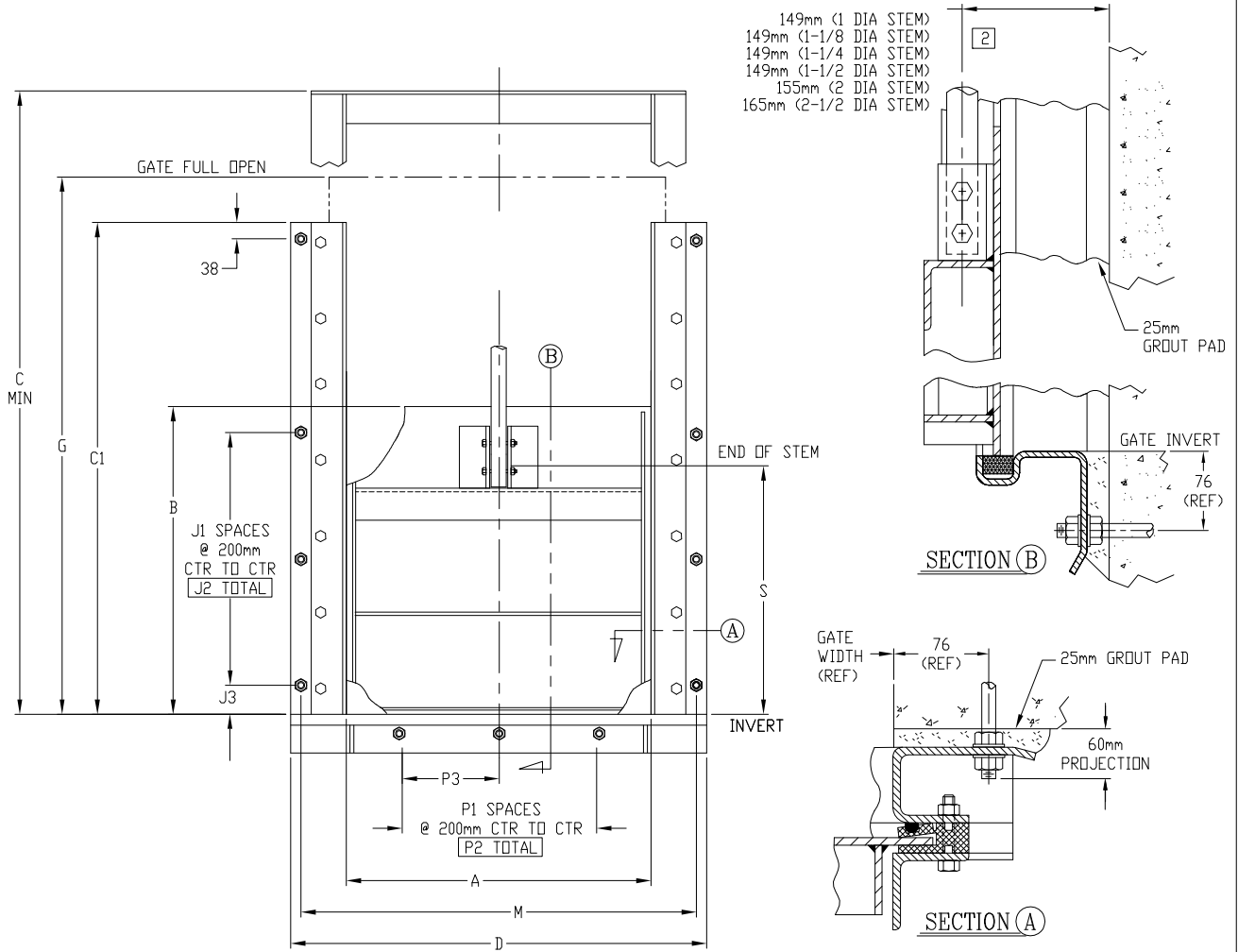

GATE SIZE A x B	C	C1	D	G	J1	J2	J3	M	P1	P2	P3	S
												(RS)
600 x 450	1104	750	854	900	2	400	25	752	2	400	200	302
600 x 600	1404	1000	854	1200	2	400	100	752	2	400	200	452
600 x 750	1704	1250	854	1500	3	600	75	752	2	400	200	602
600 x 900	2004	1500	854	1800	4	800	50	752	2	400	200	752
600 x 1050	2304	1750	854	2100	5	1000	25	752	2	400	200	902
600 x 1200	2604	2000	854	2400	5	1000	100	752	2	400	200	1052
700 x 700	1604	1167	954	1400	3	600	50	852	3	600	300	552
750 x 450	1104	750	1004	900	2	400	25	902	3	600	300	302
750 x 600	1404	1000	1004	1200	2	400	100	902	3	600	300	452
750 x 750	1704	1250	1004	1500	3	600	75	902	3	600	300	602
750 x 900	2004	1500	1004	1800	4	800	50	902	3	600	300	752
750 x 1050	2304	1750	1004	2100	5	1000	25	902	3	600	300	902
750 x 1200	2604	2000	1004	2400	5	1000	100	902	3	600	300	1052
750 x 1370	2944	2284	1004	2740	6	1200	75	902	3	600	300	1222
750 x 1500	3204	2500	1004	3000	7	1400	50	902	3	600	300	1352
800 x 800	1804	1334	1054	1600	3	600	100	952	3	600	300	652

[2] ± 4mm ON THE STEM CENTERLINE DIMENSION.

1 ALL DIMENSIONS ARE IN MM

NOTES: UNLESS OTHERWISE SPECIFIED.

SS-253-1

REVISION	DATE	APPROVED
DRAWN BY KA	CHECKED BY	
SCALE NONE	DATE 27-08-06	
DRAWING NO. 100509	SHEET 3 OF 7	

WATERMAN INDUSTRIES OF EGYPT

FOR PRELIMINARY DESIGN PURPOSES ONLY
DO NOT USE FOR INSTALLATION UNLESS
PART OF CERTIFIED & APPROVED SUBMITTAL

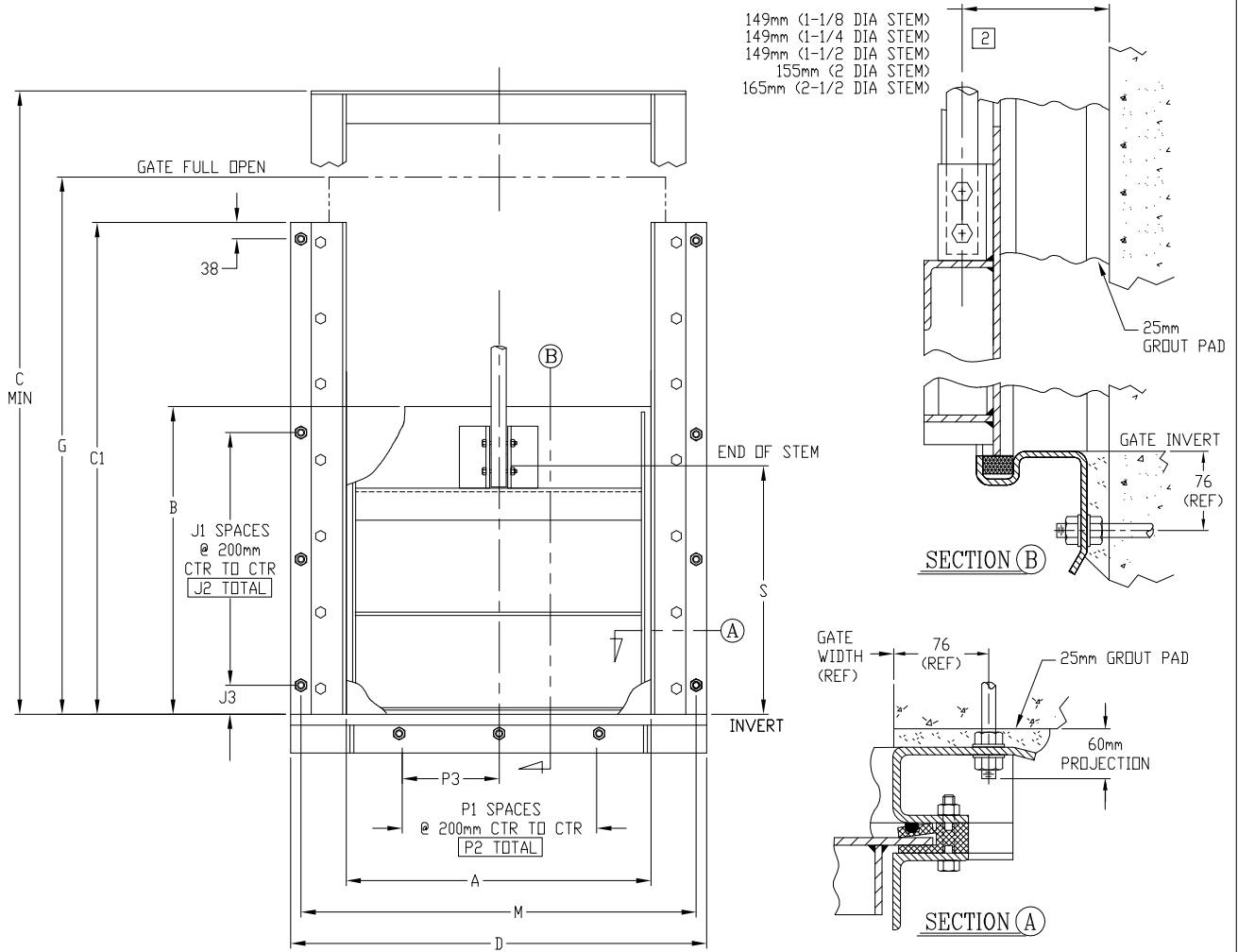

GATE SIZE A x B	C	C1	D	G	J1	J2	J3	M	P1	P2	P3	S
												(RS)
900 x 450	1104	750	1154	900	2	400	25	1052	4	800	400	302
900 x 600	1404	1000	1154	1200	2	400	100	1052	4	800	400	452
900 x 750	1704	1250	1154	1500	3	600	75	1052	4	800	400	602
900 x 900	2004	1500	1154	1800	4	800	50	1052	4	800	400	752
900 x 1050	2304	1750	1154	2100	5	1000	25	1052	4	800	400	902
900 x 1200	2604	2000	1154	2400	5	1000	100	1052	4	800	400	1052
900 x 1370	2944	2284	1154	2740	6	1200	75	1052	4	800	400	1222
900 x 1500	3204	2500	1154	3000	7	1400	50	1052	4	800	400	1352
900 x 1670	3544	2784	1154	3340	8	1600	25	1052	4	800	400	1522
900 x 1800	3804	3000	1154	3600	8	1600	100	1052	4	800	400	1652
1000 x 1000	2204	1667	1254	2000	4	800	100	1152	4	800	400	852
1050 x 600	1404	1000	1304	1200	2	400	100	1202	5	1000	500	452
1050 x 750	1704	1250	1304	1500	3	600	75	1202	5	1000	500	602
1050 x 900	2004	1500	1304	1800	4	800	50	1202	5	1000	500	752
1050 x 1050	2304	1750	1304	2100	5	1000	25	1202	5	1000	500	902
1050 x 1200	2604	2000	1304	2400	5	1000	100	1202	5	1000	500	1052
1050 x 1370	2944	2284	1304	2740	6	1200	75	1202	5	1000	500	1222
1050 x 1500	3204	2500	1304	3000	7	1400	50	1202	5	1000	500	1352
1050 x 1670	3544	2784	1304	3340	8	1600	25	1202	5	1000	500	1522
1050 x 1800	3804	3000	1304	3600	8	1600	100	1202	5	1000	500	1652

2 ± 4mm ON THE STEM CENTERLINE DIMENSION.
1 ALL DIMENSIONS ARE IN MM
NOTES: UNLESS OTHERWISE SPECIFIED.

SS-253-1

REVISION	DATE	APPROVED
DRAWN BY KA	CHECKED BY	
SCALE NONE	DATE 27-08-06	
DRAWING NO. 100509	SHEET 4 OF 7	

WATERMAN INDUSTRIES OF EGYPT

FOR PRELIMINARY DESIGN PURPOSES ONLY
 DO NOT USE FOR INSTALLATION UNLESS
 PART OF CERTIFIED & APPROVED SUBMITTAL

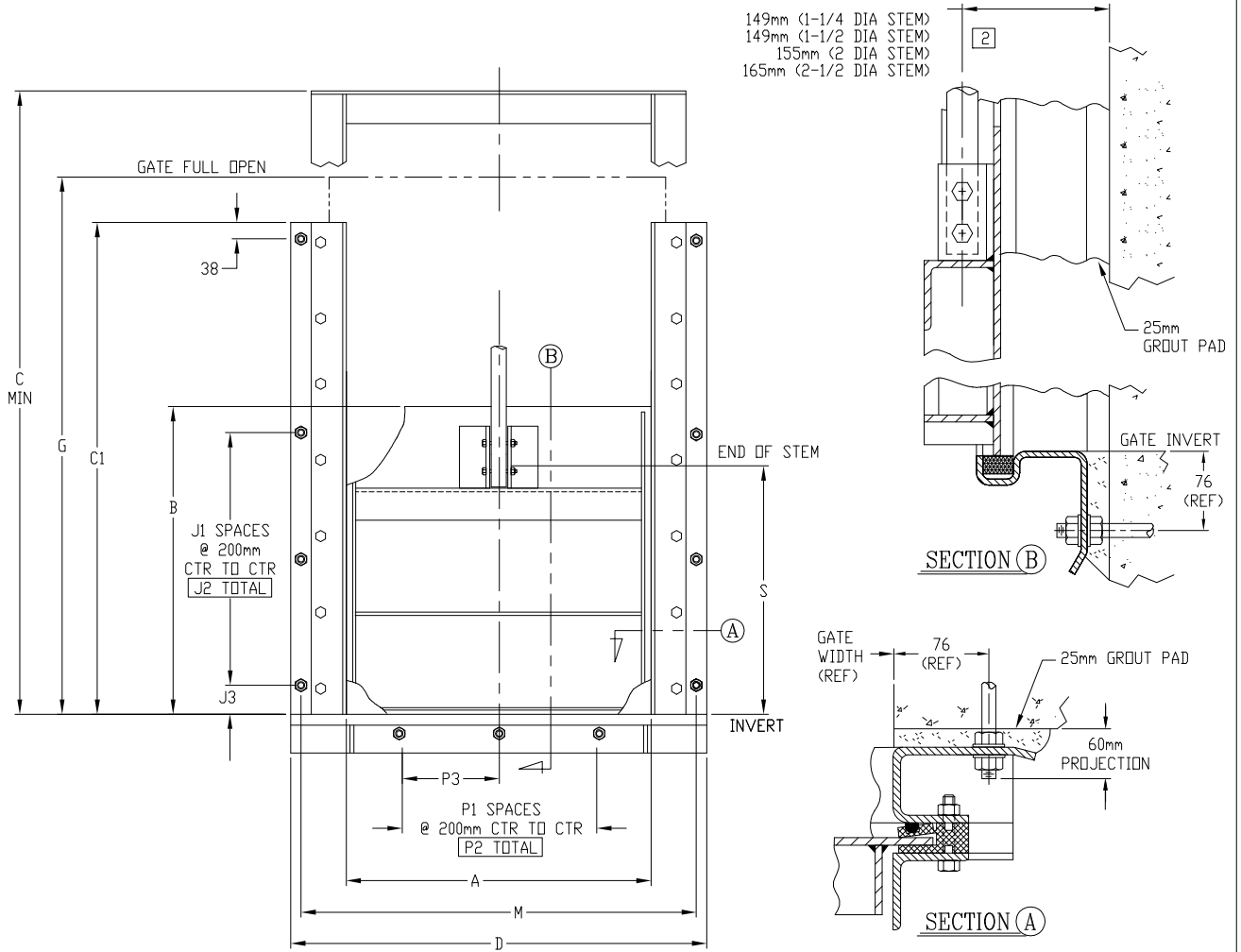

GATE SIZE A x B	C	C1	D	G	J1	J2	J3	M	P1	P2	P3	S
												(RS)
1100 x 1100	2404	1834	1354	2200	5	1000	50	1252	5	1000	500	952
1200 x 600	1404	1000	1454	1200	2	400	100	1352	5	1000	500	452
1200 x 750	1704	1250	1454	1500	3	600	75	1352	5	1000	500	602
1200 x 900	2004	1500	1454	1800	4	800	50	1352	5	1000	500	752
1200 x 1050	2304	1750	1454	2100	5	1000	25	1352	5	1000	500	902
1200 x 1200	2604	2000	1454	2400	5	1000	100	1352	5	1000	500	1052
1200 x 1370	2944	2284	1454	2740	6	1200	75	1352	5	1000	500	1222
1200 x 1500	3204	2500	1454	3000	7	1400	50	1352	5	1000	500	1352
1200 x 1670	3544	2784	1454	3340	8	1600	25	1352	5	1000	500	1522
1200 x 1800	3804	3000	1454	3600	8	1600	100	1352	5	1000	500	1652
1300 x 1300	2804	2167	1554	2600	6	1200	50	1452	6	1200	600	1152
1370 x 750	1704	1250	1624	1500	3	600	75	1522	6	1200	600	602
1370 x 900	2004	1500	1624	1800	4	800	50	1522	6	1200	600	752
1370 x 1050	2304	1750	1624	2100	5	1000	25	1522	6	1200	600	902
1370 x 1200	2604	2000	1624	2400	5	1000	100	1522	6	1200	600	1052
1370 x 1370	2944	2284	1624	2740	6	1200	75	1522	6	1200	600	1222
1370 x 1500	3204	2500	1624	3000	7	1400	50	1522	6	1200	600	1352
1370 x 1670	3544	2784	1624	3340	8	1600	25	1522	6	1200	600	1522
1370 x 1800	3804	3000	1624	3600	8	1600	100	1522	6	1200	600	1652

[2] ± 4mm ON THE STEM CENTERLINE DIMENSION.
 1 ALL DIMENSIONS ARE IN MM
 NOTES: UNLESS OTHERWISE SPECIFIED.

SS-253-1

REVISION	DATE	APPROVED
DRAWN BY KA	CHECKED BY	
SCALE NONE	DATE 27-08-06	
DRAWING NO. 100509	SHEET 5 OF 7	

WATERMAN INDUSTRIES OF EGYPT

FOR PRELIMINARY DESIGN PURPOSES ONLY
DO NOT USE FOR INSTALLATION UNLESS
PART OF CERTIFIED & APPROVED SUBMITTAL

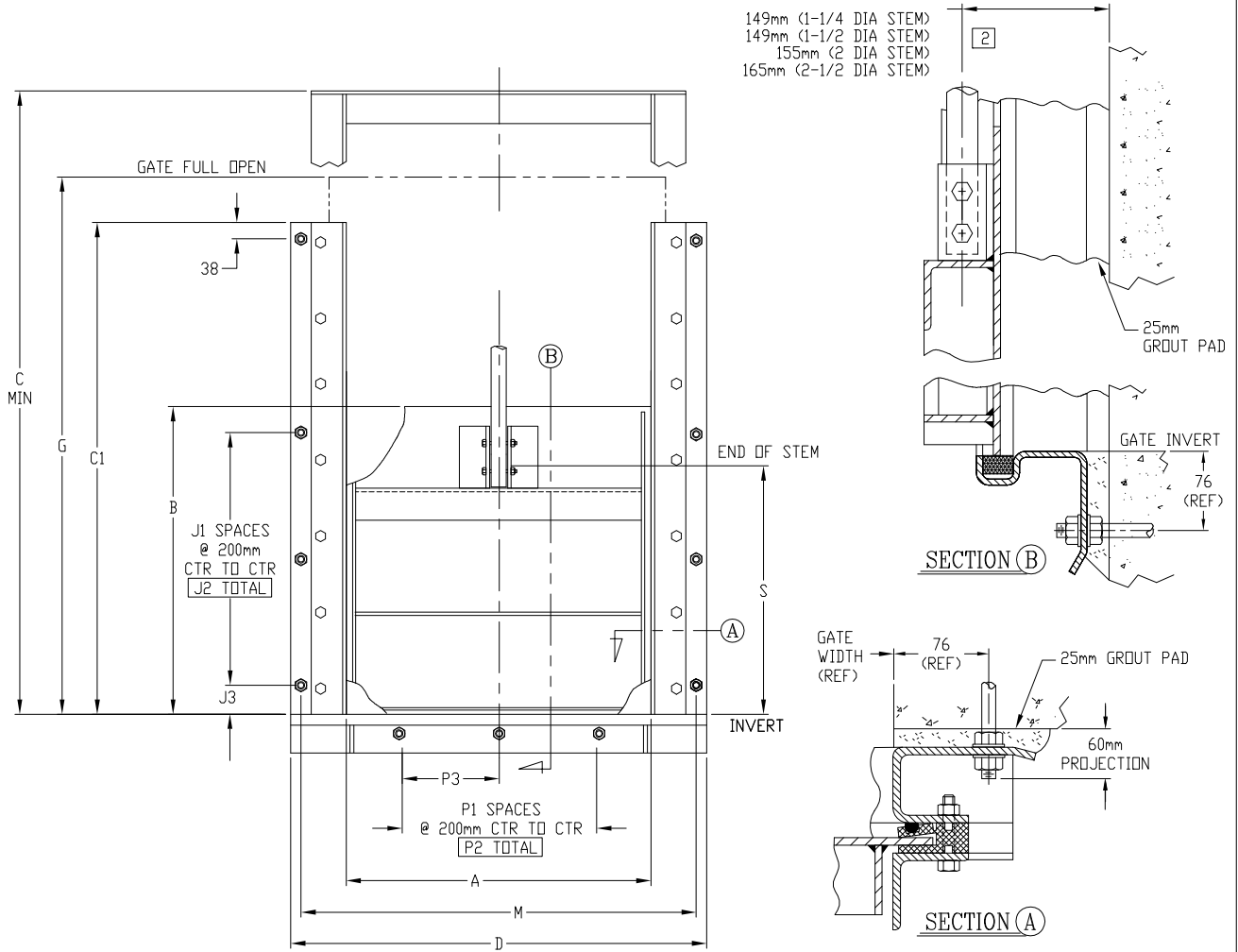

GATE SIZE A x B	C	C1	D	G	J1	J2	J3	M	P1	P2	P3	S (RS)
	1400 x 1400	3004	2334	1654	2800	6	1200	100	1552	6	1200	600
1500 x 750	1704	1250	1754	1500	3	600	75	1652	7	1400	700	602
1500 x 900	2004	1500	1754	1800	4	800	50	1652	7	1400	700	752
1500 x 1050	2304	1750	1754	2100	5	1000	25	1652	7	1400	700	902
1500 x 1200	2604	2000	1754	2400	5	1000	100	1652	7	1400	700	1052
1500 x 1370	2944	2284	1754	2740	6	1200	75	1652	7	1400	700	1222
1500 x 1500	3204	2500	1754	3000	7	1400	50	1652	7	1400	700	1352
1500 x 1670	3544	2784	1754	3340	8	1600	25	1652	7	1400	700	1522
1500 x 1800	3804	3000	1754	3600	8	1600	100	1652	7	1400	700	1652
1600 x 1600	3404	2667	1854	3200	7	1400	100	1752	7	1400	700	1452
1670 x 900	2004	1500	1924	1800	4	800	50	1822	8	1600	800	752
1670 x 1050	2304	1750	1924	2100	5	1000	25	1822	8	1600	800	902
1670 x 1200	2604	2000	1924	2400	5	1000	100	1822	8	1600	800	1052
1670 x 1370	2944	2284	1924	2740	6	1200	75	1822	8	1600	800	1222
1670 x 1500	3204	2500	1924	3000	7	1400	50	1822	8	1600	800	1352
1670 x 1670	3544	2784	1924	3340	8	1600	25	1822	8	1600	800	1522
1670 x 1800	3804	3000	1924	3600	8	1600	100	1822	8	1600	800	1652

[2] ± 4mm ON THE STEM CENTERLINE DIMENSION.
1 ALL DIMENSIONS ARE IN MM
NOTES: UNLESS OTHERWISE SPECIFIED.

SS-253-1

REVISION	DATE	APPROVED
DRAWN BY KA	CHECKED BY	
SCALE NONE	DATE 27-08-06	
DRAWING NO. 100509	SHEET 6 OF 7	

WATERMAN INDUSTRIES OF EGYPT

FOR PRELIMINARY DESIGN PURPOSES ONLY
DO NOT USE FOR INSTALLATION UNLESS
PART OF CERTIFIED & APPROVED SUBMITTAL

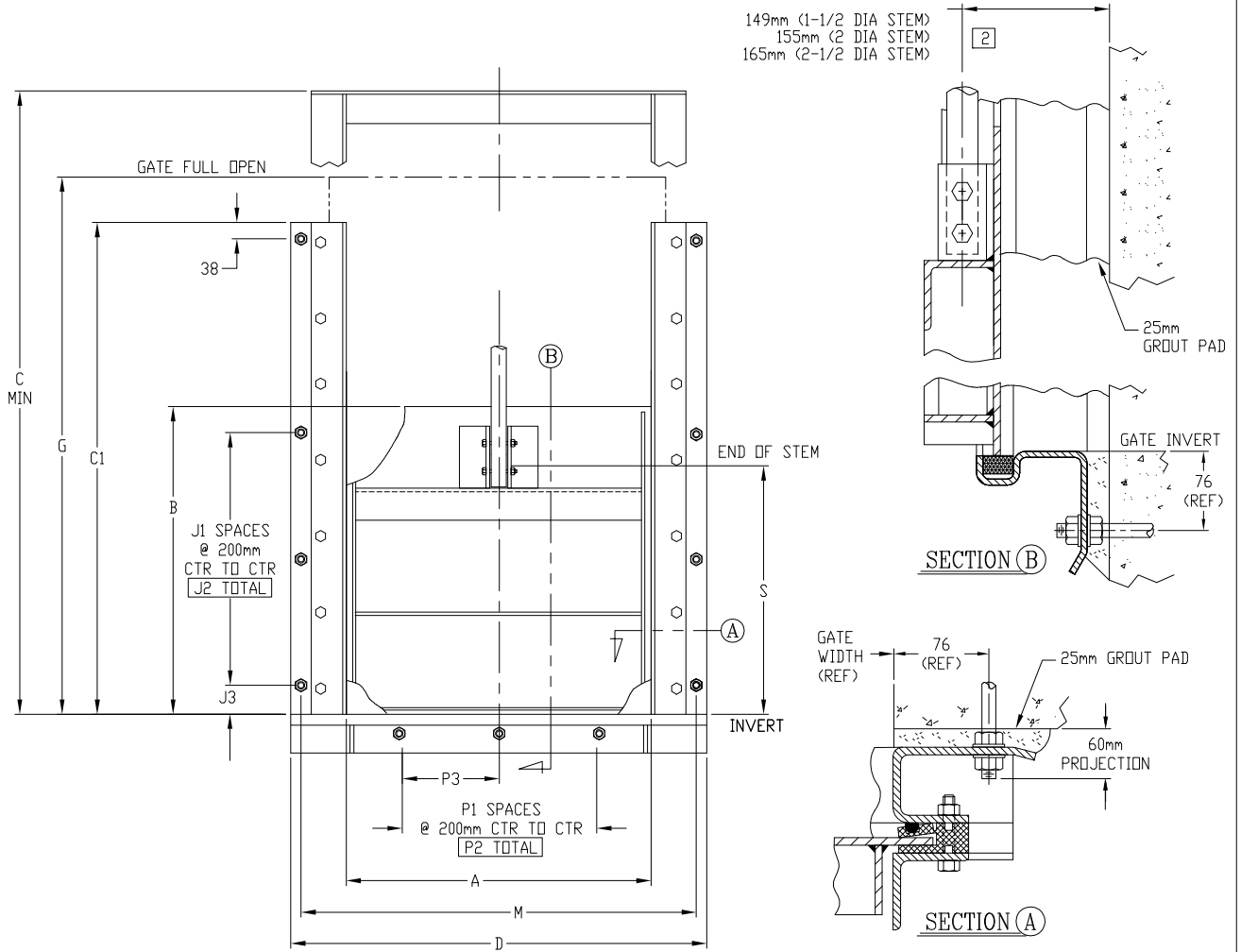

GATE SIZE A x B	C	C1	D	G	J1	J2	J3	M	P1	P2	P3	S
												(RS)
1700 x 1700	3604	2834	1954	3400	8	1600	50	1852	8	1600	800	1552
1800 x 900	2004	1500	2054	1800	4	800	50	1952	8	1600	800	752
1800 x 1050	2304	1750	2054	2100	5	1000	25	1952	8	1600	800	902
1800 x 1200	2604	2000	2054	2400	5	1000	100	1952	8	1600	800	1052
1800 x 1370	2944	2284	2054	2740	6	1200	75	1952	8	1600	800	1222
1800 x 1500	3204	2500	2054	3000	7	1400	50	1952	8	1600	800	1352
1800 x 1670	3544	2784	2054	3340	8	1600	25	1952	8	1600	800	1522
1800 x 1800	3804	3000	2054	3600	8	1600	100	1952	8	1600	800	1652

[2] ± 4mm ON THE STEM CENTERLINE DIMENSION.
1 ALL DIMENSIONS ARE IN MM
NOTES: UNLESS OTHERWISE SPECIFIED.

SS-253-1

REVISION	DATE	APPROVED
DRAWN BY KA	CHECKED BY	
SCALE NONE	DATE 27-08-06	
DRAWING NO. 100509	SHEET 7 OF 7	

WATERMAN INDUSTRIES OF EGYPT